

FRADENPROBE® Model FP-132A Installation/Operating Instructions

Introduction

The **FRADENPROBE**® air velocity transducer was developed as an OEM product intended to be integrated with a system that requires air flow measurement input for control. The model FP-132A detects air flow up to 2500 feet per minute and produces two outputs, one from 0.5V to 4.5V DC, the other a +5V PWM signal from 10% to 90% duty cycle from 0 to 2500 FPM. Air flow rates greater than 2500 FPM result in the outputs dropping to a zero air flow reading of 0.5 VDC and 10% duty cycle.

Installation

Four wires are provided for interface to control systems:

- Red - Power Supply +5.5V DC to +15V DC
- Black - Power Supply Ground, 0V DC
- Brown - Analog Output Signal, V_{out}
- Green - PWM Output Signal, Pulsed 0 to +5V DC
- White - Non-Linear Output used for calibration only

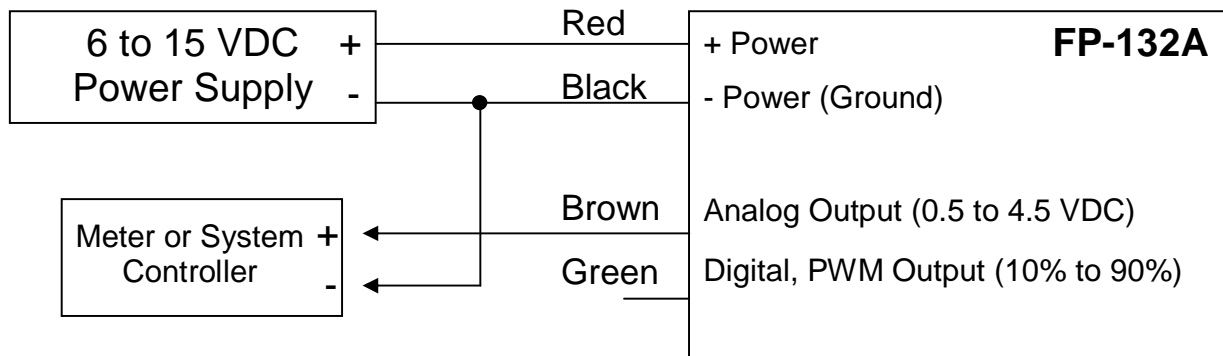

Correct orientation is required for proper operation. Align the notch on the cable end with the source of air flow (air flow should strike the **FRADENPROBE**® on the side of the housing having the notch on the cable end). When measuring air flow within a duct, the best mounting position is to have the sensor tips located at or near the center of the duct.

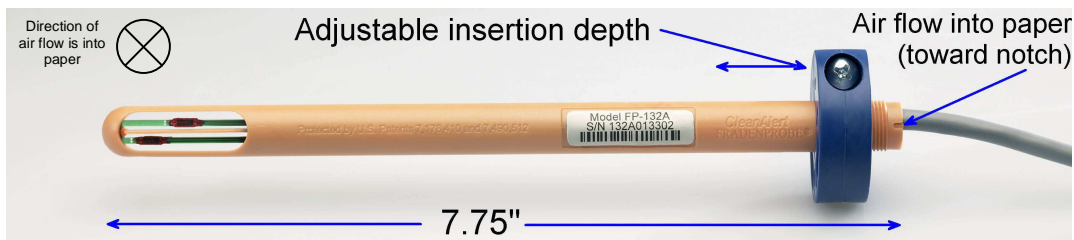

The following chart illustrates how the mounting angle typically affects the **FRADENPROBE®** output voltage. The **FRADENPROBE®** is calibrated with air flowing from right to left in the illustration. This shows a -5% to +5% angular variation as the **FRADENPROBE®** is rotated within the Mounting Block from the zero degree calibrated position, from approximately -12° to +60°.

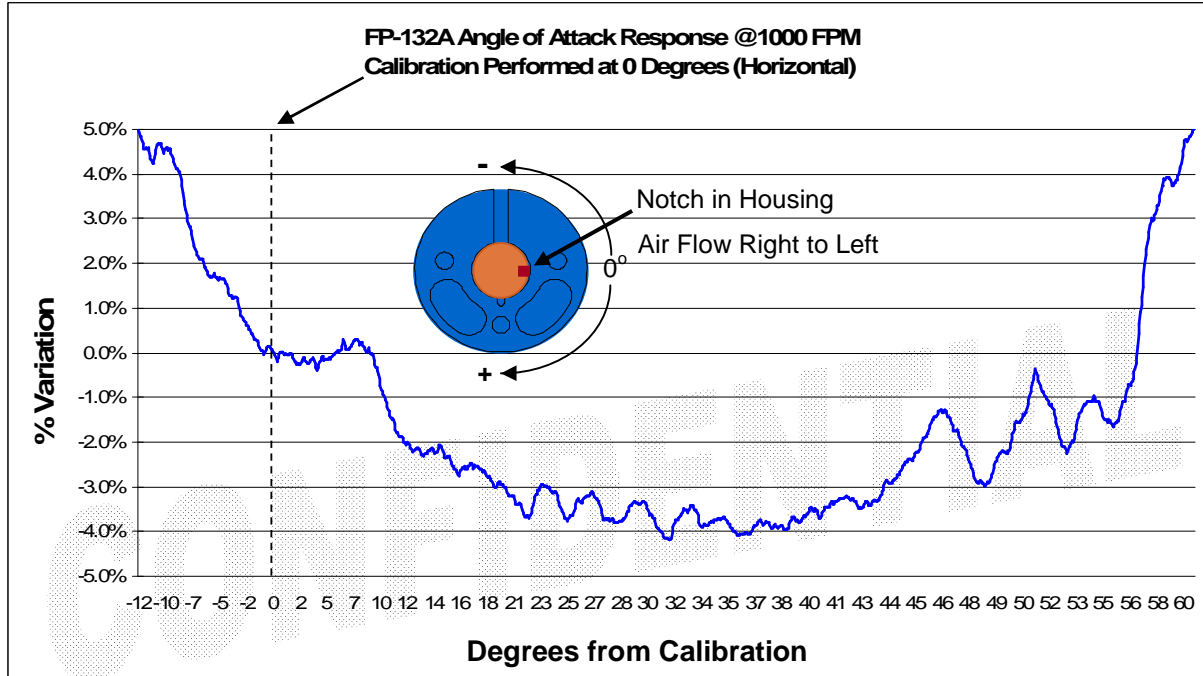

FCC COMPLIANCE

This device complies with Part 15 of the FCC Rules. Operation is subject to the following two conditions: (1) this device may not cause harmful interference, and (2) this device must accept any interference received, including interference that may cause undesired operation.

NOTE: This equipment has been tested and found to comply with the limits for a Class B digital device, pursuant to Part 15 of the FCC Rules. These limits are designed to provide reasonable protection against harmful interference in a residential installation. This equipment generates, uses and can radiate radio frequency energy and, if not installed and used in accordance with the instructions, may cause harmful interference to radio communications. However, there is no guarantee that interference will not occur in a particular installation. If this equipment does cause harmful interference to radio or television reception, which can be determined by turning the equipment off and on, the user is encouraged to try to correct the interference by one or more of the following measures:

- Reorient or relocate the receiving antenna.
- Increase the separation between the equipment and the receiver.
- Connect the equipment into an outlet on a circuit different from that to which the receiver is connected.
- Consult the dealer or an experienced radio/TV technician for help.

Mounting

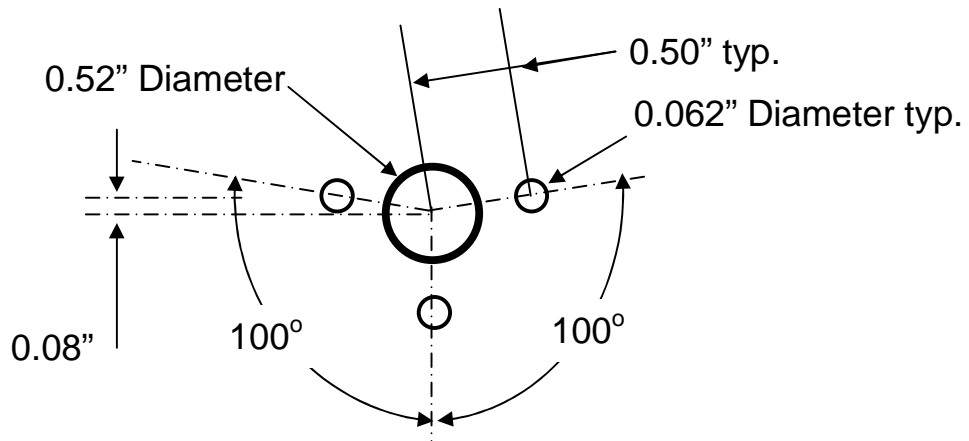

NOTE: There is a 1/2-28 UNEF Thread on the wired end of the FRADENPROBE to allow for extension.

CONFIDENTIAL

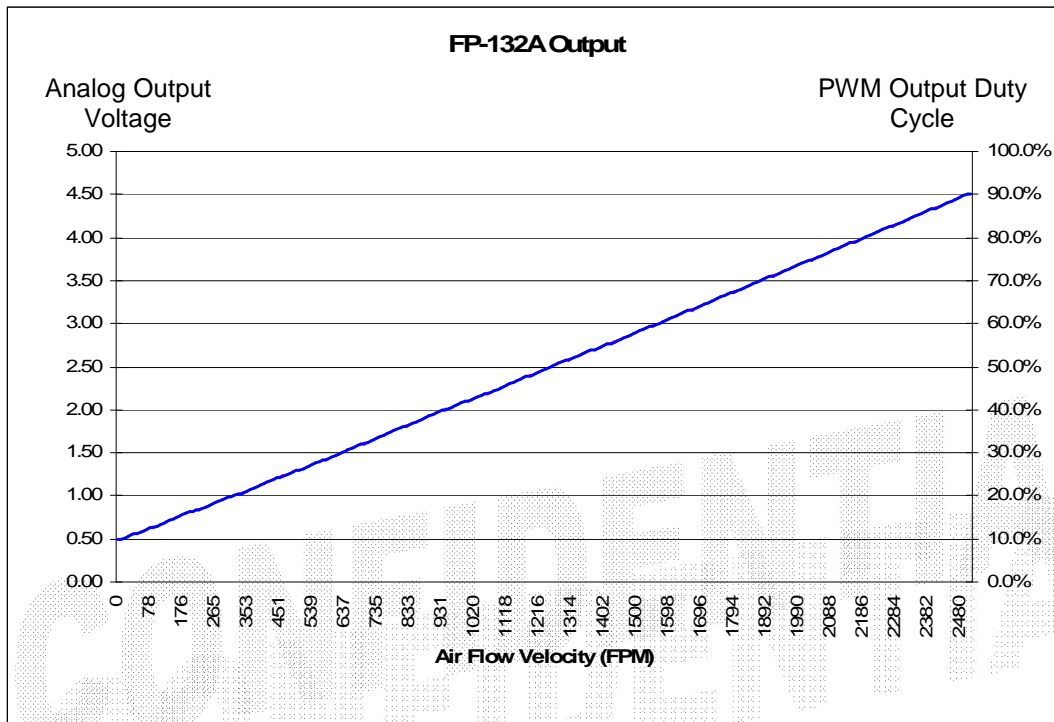

ANALOG OUTPUT: To convert Analog Output voltage to FPM: $(V_{out} - 0.5) * 625 = \text{FPM}$
PWM OUTPUT: 10%=Zero air flow, 90%=2500 FPM air flow

Specifications

Velocity Range:	40 to 2500 FPM (0.20 to 12.7 m/s)
Accuracy:	$\pm 5\%$ of Reading from 200 to 2500 FPM $\pm 5\%$ of Reading, ± 10 FPM below 200 FPM
Response Time:	Less than 20 seconds from zero to 95% of measured air flow rate
Power-on Warm up Time:	Less than 30 seconds
Temperature range:	0° to +122° F (-18° to +50° C) Operating -40° to +257° F (-40° to +125° C) Storage
Humidity:	80% RH, non-condensing
Output Formats:	0.5 to 4.5 VDC linear analog output (max load: 18mA), and Pulse Width Modulation (PWM), from approximately 10% to 90% duty cycle over the measurement range at 60Hz frequency (max load: 18mA)
Electrical Connections:	Ground, Power, Analog and PWM Outputs
Power Supply Requirements:	6 to 15 VDC at 18 mA
Probe Size:	7.875" x 0.5" Diameter
Mounting Collar:	1.5" Diameter
Extension Thread:	1/2-28 UNEF
Insertion Depth:	1.5" to 7.1"

Note

The data contained herein are furnished for information only and are believed to be reliable. We cannot assume responsibility for the results obtained by others over whose methods we have no control. It is the user's responsibility to determine suitability for the user's purpose and to adopt such precautions as may be advisable for the protection of property and of persons. In light of the foregoing, **CleanAlert, LLC specifically disclaims all warranties expressed or implied, including warranties of merchantability or fitness for a particular purpose, arising from sale or use of CleanAlert, LLC's products. CleanAlert, LLC specifically disclaims any liability for consequential or incidental damages of any kind, including lost profits.** The discussion herein of various applications is not to be interpreted as representation that they are free from domination of patents owned by others or as a license under any **CleanAlert, LLC** patents that may cover such applications. We recommend that each prospective user test his proposed application before use, using this data as a guide.

CleanAlert products are manufactured under one or more of the following U.S. Patents: 7,178,410 7,490,512
Specifications are subject to change without notice.

CAFPOP132101026